

CellScale for the Steel Industry

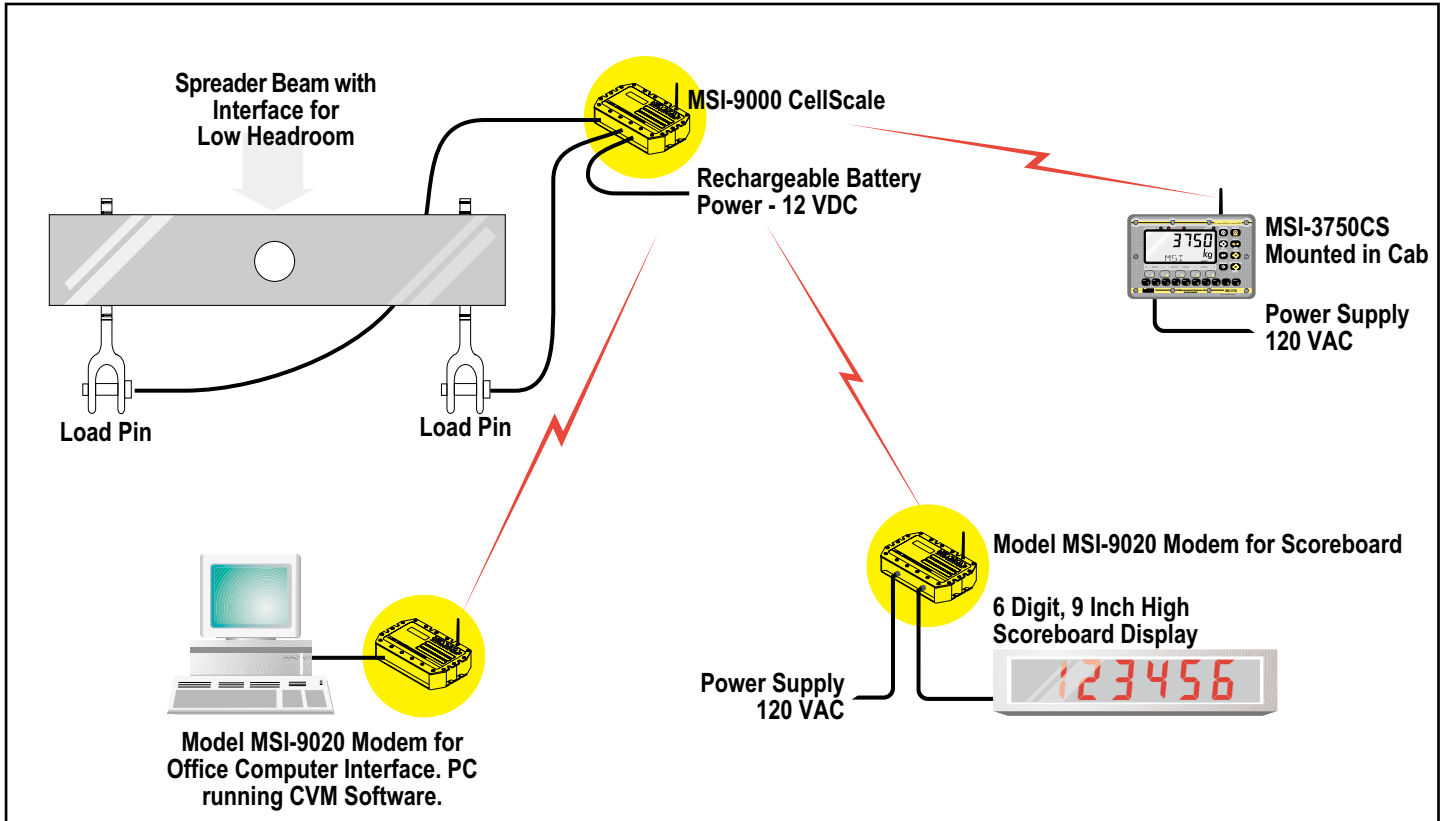

Application Objective

A steel producer wanted to integrate a weighing system in an existing spreader beam specifically designed with a special low headroom lifting interface. The purpose of the weighing system was to improve process control and production yield monitoring without increasing headroom.

Solution

MSI-9000 CellScale interfaced to load pins specifically designed for the lifting interface. The CellScale RF network is set up to

communicate with the MSI-3750CS Digital Weight Indicator and two MSI-9020 CellModems.

Features and Benefits

The compact packaging and versatile mounting of the standard CellScale enabled direct mounting to the spreader beam, minimizing alterations and reducing installation time. CellScale's advanced RF technology provides a seamless interface with multiple peripheral devices to supply weighment data at the desired locations.

Including an office computer running CVM software that enables the PC to act as a desktop digital scale indicator. The use of CVM software provided the customer with the ability to capture and store all weighment information in an easily accessible database file. Production yields and process variables are data logged, analyzed and used to drive process improvements.

Contact MSI now for more information on Cellular Weighing and/or to arrange an application review and proposal.