

MSI 4300/7

PORTA-WEIGH PLUS
CRANE SCALES
7 KEY VERSION

User Guide

*Quality
Industrial
Weighing
and Force
Measurement
Equipment*



*Measurement
Systems
International*

TABLE OF CONTENTS

General Description	3	Specifications	44
Unpacking	3	Options	46
Liquid Crystal Display	3	The MSI Limited Warranty	47
Backlight	4	Proper Loading Procedures	48
Batteries	4		
Standard Features	5		
Infrared Remote Control Features	6		
Quick Keyboard Operation	7		
Shifted & Secondary Functions	7		
Operation Guide	8		
POWER	8		
ZERO	9		
NET/GROSS	10		
TARE	11		
TOTAL	12		
VIEW Σ (total)	15		
TEST	16		
SETUP	16		
FILTER	18		
UNITS	18		
AUTO OFF	19		
Infrared Remote Control	20		
Lighting	20		
Contrast	21		
HI SETPT (Setpoint)	21		
LO SETPT (Setpoint)	22		
Set Point Entry	22		
To Disable a Set Point	24		
PEAK HOLD	25		
Tare Memory	26		
CLEAR	29		
SELECT	30		
ENTER	30		
System Initialize	30		
Calibration (front panel)	31		
EIA-232-D Serial Output Option	34		
Operation	36		
Computer Operation of the MSI Porta-Weigh Plus	37		
Porta-Weigh Plus Basic Programming Example	39		

GENERAL DESCRIPTION

The Measurement Systems International Porta-Weigh Plus crane scale represents a new level of technology and performance in the scale industry. The MSI-4300 Porta-Weigh Plus is a computerized, self-contained, battery-operated crane scale. The scale is made up of three separate sections which house the electronics, load cell and battery. The sections are bolted together and sealed against moisture by the use of O-rings. The scale housing is made of impact resistant cast aluminum alloy. All electronics are shock mounted and the recessed display window is impact resistant ADC Monomer that is much tougher than polycarbonate.

A 16 bit microcontroller coupled with an alphanumeric display gives unprecedented versatility and programmability. The advanced power saving circuitry provides in excess of 2000 hours of operating time from ordinary D cell alkaline batteries. The large, backlit, alphanumeric display provides precise, unambiguous indication of operating modes such as net, gross, and total. Digital calibration makes maintaining the scale a snap, and the single printed circuit board, fully shock-mounted, marine-proof construction makes for a rugged and reliable scale. To further enhance the versatility of the Porta-Weigh Plus, a ruggedized, marine-proof, infrared remote control system can access and control all the operating modes of the scale. The scale is designed to meet or exceed the requirements of all regulatory agencies.

UNPACKING

When unpacking the scale from the shipping container, ensure that all parts are accounted for. Check the scale for any visible damage and immediately report any to your shipper. It is advisable to use the original shipping container when shipping or transporting the Porta-Weigh Plus.

LIQUID CRYSTAL DISPLAY

The Porta-Weigh Plus is equipped with a large Liquid Crystal Display (LCD) providing both weight indication and setup parameters. The LCD is optimized for viewing in a cone beneath the scale, as the scale is primarily used overhead. Direct head height viewing angle is compromised. The best contrast is achieved when the scale is about a foot or more above head height.

BACKLIGHT

A display light for low light operation is standard with the Porta-Weigh Plus. This light is activated and deactivated by a photocell which senses ambient light levels. In the "Automatic" mode, no controls are required to activate the back light. Under the SETUP menu (see SETUP in the operation instructions), the backlight can be fixed on, fixed off, or set in the default AUTOMATIC mode.

If battery life is the primary consideration in using the Porta-Weigh Plus, the backlight should be forced off (see SETUP). The backlight alone uses 8 times the energy normally consumed by the scale. If the backlight is left off the Porta-Weigh Plus will achieve greater than 2000 hours of operation.

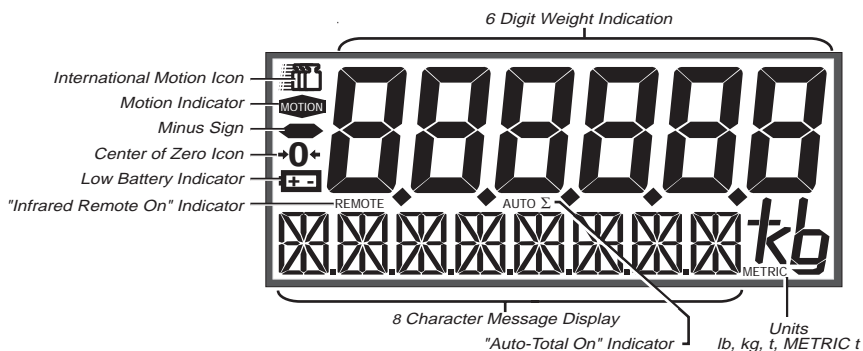

Liquid Crystal Display Detail

BATTERIES

Type:
8 Standard "D" cells (NEDA/ANSI 13A, IEC LR20). Alkaline type is preferred. Standard Carbon-Zinc can also be used, but this cuts the available battery life in half.

Installing and Changing:

- 1) The batteries must have enough charge to ensure accurate operation. (8 batteries in series must total more than 5.5V).
- 2) Turn the scale off.
- 3) Remove the battery tubes by turning the knobs counterclockwise. It is not necessary to remove both tubes at once.
- 4) Replace the batteries with four fresh "D" cells in each tube;

- polarity is indicated on the tube.
- 5) Reinstall the battery tube by inserting the tube back into the scale and turning the knobs clockwise.
 - 6) Option: The batteries can be checked with the test mode. Power displayed is in relative percent of battery life. If the number with fresh batteries is extremely low, (<10%) turn power off, remove the tubes and check that the polarity of all batteries are correct.

Rechargeable Batteries:

The Porta-Weigh Plus will operate efficiently with standard Ni-Cad "D" cells. Batteries must be charged in an external battery charger. Expect scale operation time to be from 1/4 to 1/2 that of alkaline.

STANDARD FEATURES

- Designed to meet or exceed all US and international standards.
- Rugged construction throughout. Single PCB is shock mounted and can withstand shocks in excess of 50G's. Switches are totally sealed and rated for over 10 million operations.
- Precise high resolution 16 bit A/D conversion coupled with advanced 16 bit Microcontroller provides world class features and accuracy.
- Six large, 1.65 inch high digits for clear weight readings from a distance.

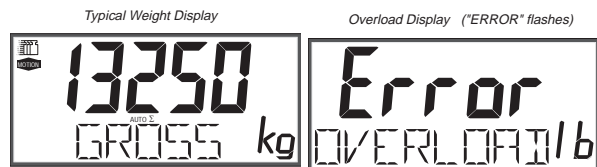

- Easy to read annunciation of measurement modes such as NET or GROSS are provided on nine .825 inch high alphanumeric characters. These are also used for menu prompts.
- Display illumination uses long life, EL backlighting coupled with a transfective liquid crystal display. This provides optimum display contrast under all ambient conditions from full sunlight to total darkness. Operation is light-sensing automatic or manually set.
- Exceptional battery life: Typically 2000 hours of continuous

use provided by 8 alkaline ‘D’ cells. Maximum battery life is reduced by use of the backlighting; full time low light operation will provide up to 400 hours of operation. A typical operating cycle of 8 hours daylight use and 2 hours night use will provide 10 months of operation on a single battery.

The Porta-Weigh Plus will automatically power down when not in use (this feature can be disabled). And a low battery indication appears when approximately 10% of battery life remains.

- Easy to maintain: Full digital calibration assures reliable, repeatable measurements.
- Selectable for lbs, kg, tons, and metric tons unless prohibited by regulations.
- Automatic or manual weight totalization for loading operations.
- Complete marine sealing ensures reliable operations under harsh weather conditions.
- Anti-EMI shielding standard. Low emissions and susceptibility.
- Easily customized for special applications.
- Up to 10 recallable Tare memories stored manually or automatically.
- Peak Hold mode for stress analysis.
- 2 set points can be set for any in-range weight for operator alerts or process control. External setpoint outputs available. (Contact factory for information).
- Silicon elastomeric rubber switches, which are more rugged than mechanical switches, provide 10 million operations. They can withstand excessive impact without affecting operation. Rubber membrane provides watertight seal. Additional poly shield on underlay provides second layer of integrity and prevents humidity contamination.

INFRARED REMOTE CONTROL FEATURES

The infrared remote control option allows all features of the scale to be operated at distances up to 10 meters from the scale. This rugged option is shock proof and waterproof. In addition to remote operation of all the standard modes of the scale the following features are added:

- 9 ID codes. This feature provides the user with the ability to store up to 9 separate totalizations. Keeping track of individual loads is simpler than ever. Each of the 9 totalizations can go up to 999999 counts.
- Numeric entry of tare values and set points.

QUICK KEYBOARD OPERATION

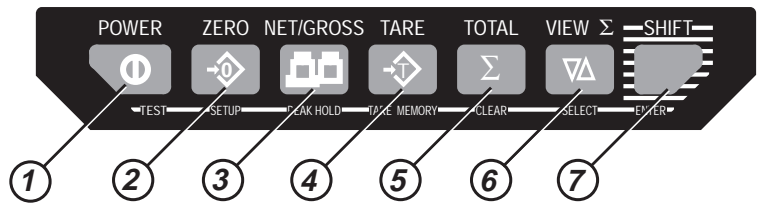

1. **POWER:** Turns the scale on and off.
2. **ZERO:** Zeros the scale. Has full range to 100% of scale (except for some legal for trade units).
3. **NET/GROSS:** Toggles the display between GROSS and NET modes. To enter NET mode, a valid tare value must be stored.
4. **TARE:** In GROSS mode, pushing this switch stores the current weight reading as a tare value and switches the unit to the NET mode. When in NET mode, pushing this switch provides a brief display of the Tare value.
5. **TOTAL:** Pressing this will add the current weight to the Total Register. The scale must return to zero before this button can be used again. When in Auto Total mode, this key is an Auto Total On, Auto Total Off toggle.
6. **VIEWΣ:** Displays the total weight accumulated and the number of weighments.
7. **SHIFT:** Used to shift to secondary functions and as an enter key when inputting variables.

SHIFTED & SECONDARY FUNCTIONS

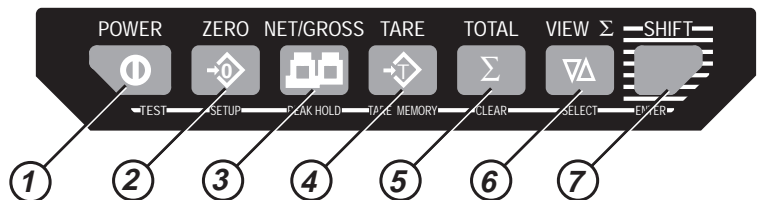

1. **SHIFT POWER/TEST:** Completes an LCD test, an internal function test, indicates % remaining battery life and displays the R calibration number.

2. **SHIFT ZERO/SETUP:** Enables the setup menus. Controls for Units, Filtering, Backlight, Set Points, IR Remote, Auto Power (off), and Total mode are found in the Setup menu. (Legal-for-trade units may have a subset of these functions).
3. **SHIFT NETGROSS/PEAKHOLD:** Enables/disables the Peak-Hold function. The highest reading is captured. Use Shift-Clear to erase the current peak.
4. **SHIFT TARE/TARE MEMORY:** Enables the Tare Memory menu. Use the Select and Enter yes to store and/or apply up to 9 tare values.
5. **SHIFT TOTAL/CLEAR:** Used to Erase (Clear) Peak-Hold values and numeric values. The Clear function is also a useful shortcut out of various setup menus.
6. **SHIFT VIEW Σ /SELECT:** The select key is used to scroll through various menu choices in Setup, Tare and Calibration menus. It is also used to input numbers for Setpoints, Tares and Calibration.
7. **SHIFT:** Used in conjunction with the Select key to enter selected values or parameters. This function of the Shift key is only active when it is needed.

OPERATION GUIDE

POWER

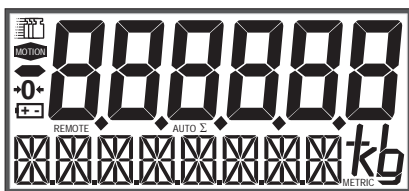

Function:

Turns the Scale On/Off (toggle action).

Use:

- 1) The batteries must have enough charge to ensure accurate operation. (8 batteries in series must total more than 5.4V).
- 2) Ambient temperature must be greater than -30°C and less than 60°C (-22° to 140°F).

Action:

- 1) Push POWER button.

- 2) Display Check: All segments and the Total LED are illuminated for 1 second.
- 3) Message displays “MSI PAW+”, numerics give the software version number (1 second).
- 4) During display test and MSI message, all internal operations are checked and any nonconformance causes an error message to be displayed.

Final:

Unit reads the current weight in the last set mode (NET, GROSS, VIEW TOTAL, PEAK NET, PEAK GROSS).

ZERO



Function:

Sets the zero reading of the scale.

Use:

- 1) The scale must be stable. The scale will not zero if the motion detect annunciator is on.
- 2) The scale must be in the Gross mode. The scale will not zero in the Net or Total modes.
- 3) The scale will accept a zero setting over the full Range of the scale (Legal-for-trade models might have a limited zero range). Zero settings will subtract from the overall capacity of the scale. For example, if you zero out 1000 lbs on a 5000 lb scale the overall capacity of the scale will reduce to 4000 lbs plus the allowed overrange amount.

Action:

Push ZERO button.

The weight reading must be stable within ± 1 division. If this condition is met the display reads “ZEROED” and the digits display 0 (or 0.0 or 0.00 depending on resolution). The zero setting is stored by the backup memory, which will restore it the next time the system is turned on.

NET/GROSS



Function:

Switches the display between Net and Gross modes. Net Weight is defined as Gross Weight minus the Tare Weight.

Use:

- 1) There must be a Tare weight established to switch from Gross mode to Net mode (See Tare).
- 2) NET/GROSS will work even when the scale is in motion.

Action:

Push NET/GROSS.

- No current tare is stored (Tare = Ø).
No Action, display continues to read the Gross weight only.
- A tare value is stored:
Toggles between Net and Gross display modes. Display reads "GROSS" or "NET".

Note: The NET/GROSS key also functions while in the PEAK HOLD mode. There is not a separate maximum value for PEAK NET and PEAK GROSS. PEAK NET is computed from maximum gross minus the tare value.

Final:

The display reads "GROSS" and the digits display "0" (or 0.0 or 0.00 depending on resolution).

TARE



Function:

Stores a Tare Weight (Gross Weight mode) or...Displays temporarily the Tare Weight (Net Weight mode).

Use:

- 1) Only positive weight readings can be tared.
- 2) The scale will only tare when it is in the GROSS mode
- 3) The motion annunciator must be off, the weight reading must be stable. The weight reading must be stable within ± 1 division (Motion annunciator off).
- 4) Setting or changing the tare has no effect on the zero setting.
- 5) Taring will reduce the apparent overrange of the scale. For example, if a 1000lb container was tared and the scale capacity is 5000lb, the scale will overload at a net weight of 4000lb (5000-1000) plus any additional allowed overload (usually ~4%).
- 6) The tare value is stored in the backup memory, which will restore it the next time the system is turned on.

Action:

Push TARE

- The scale must be in the GROSS mode: The entire range of the scale can be Tared. If the motion condition is met the display temporarily reads "TARE SET" and then converts to a "NET" display and the weight digits register \emptyset . All subsequent readings are deviations from the set Tare value.

Final:

- Tare is set, displaying NET weight.
Any subsequent pushes of the TARE key will display the Tare value temporarily unless the NET/GROSS key is used to return to the Gross reading.

To remove the Tare Value:

Without erasing the value, push NET/GROSS. The Tare will remain in memory until a new tare value is stored.

Note: A factory option is available that will erase the Tare by pushing the TARE key when the weight is at zero.

TOTAL

Function:



For accumulation of multiple weighments. The accumulator always uses the displayed weight, so Gross and Net readings can be added into the same total. There are two modes of Totalizing which are set in the Calibration SETUP section. The Manual mode requires that the TOTAL key is pushed when the weight currently on the scale should be added to the previously accumulated value. The Auto mode will automatically add the last, settled, stable, value to the total. Both modes require that the weight on the scale returns within 1% (relative to full scale) of Gross Zero or Net Zero before the next weighing can be added. Applied weight must be 2% of full scale or “Min e” (whichever is greater) above Gross Zero or Net Zero before it can be totaled.

Manual Total:

Use:

- 1) The motion annunciator must be off, the scale must be stable ± 1 division. If there is considerable motion on the scale, use the Medium or High Filter setting (see SETUP).
- 2) Only positive readings can be accumulated.
- 3) After a weighment is totaled, the weight on the scale must return to below 1% of full scale capacity relative to Gross Zero or Net Zero before another weight can be added to the total. This assures that a weight on the scale is only added to the total once.
- 4) When the total weight exceeds the display capability of 999,999 counts, or the total count exceeds 9999, dashes will

appear to reflect a display overflow. If you have a printer option, the larger numbers can be printed through the use of the PRINT button on the Remote, or with a computer hookup.

Action:



Push TOTAL

The current weight is added to the total register. The total weight along with the number of weighments is displayed briefly on the LCD. (See VIEW TOTAL)

- Weight greater than 2% of full scale or “Min e” whichever is greater (settable parameter-contact factory) :
Add the current reading (relative to the tared zero or Gross zero depending on mode) to the contents of the accumulate register.
- When a valid value is added, the display gives an indication of the new total and how many weighments have been totaled. i.e. 1 TOTAL , 2 TOTAL , 3 TOTAL, ...x TOTAL. The Total accepted LED (center right of display) will also light for 4 seconds providing additional indication that the Total command was accepted.

To Clear the total:

Press VIEWΣ, SHIFT & CLEAR .

Press VIEWΣ to exit View Total.

Auto Total:

Setup Option:

Allows for auto accumulate. When a weight threshold of 2% of full scale or “Min e” (whichever is greater) above Net Zero or Gross Zero is exceeded the accumulate function operates automatically. The displayed weight is added to the accumulated value in the Total Register only when the weight returns to zero (0±1% of full scale). When a weight that meets the minimum accept limit, settles (no motion), the Total LED indicator will flash three times. If the weight changes to a new settled value the LED will flash again indicating that

the previous settled reading has been replaced. The last settled reading is what will be used for totalizing when the scale returns to zero. The user must take caution that when removing the load the scale does not go out of Motion or a possibly erroneous reading could occur. The last settled weight is actually added to the total when the scale returns to less than 1% of full scale. The Total LED will flash for a steady 4 seconds indicating the weight has been totaled and the total value will be shown briefly.

Note: MSI can modify or supply the Porta-Weigh Plus with a “maximum settled weight mode” AutoTotal. Contact factory for details.

Action:

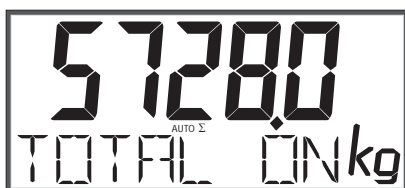

Push TOTAL.

- 1) The message "TOTAL ON" appears briefly, then "AUTO Σ" annunciator.
- 2) Pick up the weight to be totalized. The LED will flash three or more times when the weight is settled.
- 3) Set down the weight. The screen displays the new total and will indicate "x TOTAL" where x is the number of totaled weighments up to 9999.
 - The total key is used as a Total Enable, Total Off, toggle key which is indicated briefly on the message display (i.e. "TOTAL ON" or "TOTAL OFF"). Auto Totalizing will only occur in the TOTAL ON mode.
 - The Auto Total On mode is indicated by an "AUTO Σ" annunciator on the LCD .

Rules for Auto Total:

- 1) The scale cannot be in motion. An auto total acceptable reading is indicated by three or more short flashes of the Total LED.
- 2) Weight readings must be greater than 2% of FS or “Min e” (whichever is greater) relative to Net Zero or Gross Zero.
- 3) Each reading added to total must be preceded by a return to zero (Net or Gross) $\pm 1\%$ of FS. Totalization of the last settled weight is indicated by a 4 second flash of the Total LED.

VIEW Σ (TOTAL)**Function:**

Displays the current Total value and allows the total to be cleared.

Action:

To display the current Total Value:

Press VIEW Σ .

The message display will read “TOTAL” and the total value is displayed on the numeric digits. The Total Value will stay displayed until VIEW Σ is pushed again. The number of totalized weighments is displayed on the far left of the message display.

To clear a stored Total Value:

While in the “VIEW Σ ” mode, press VIEW Σ , SHIFT & CLEAR .

The total reading and the number of weighments counter will revert to zero.

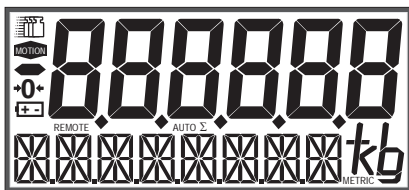
TEST
**Function:**

Provides a functional system test, and an on-demand display check without disturbing the current weighment. Also provides calibration verification in the form of a load cell Calibration number.

**Action:**

To start the test sequence: Press SHIFT & POWER.

- 1) All digits (7 segment and 16 segment) count once from 0 to 9. All annunciators are tested including lb, kg, t, and the Total LED.
- 2) Battery condition is displayed next in the form: % of Battery life with a figure from 1 to 100 on the digits. The % battery life will vary depending on whether the backlight is on or off.
- 3) The CAL number is displayed next. To ensure that the CAL number is accurate the scale must be unloaded and in the same units that it was calibrated in. The original CAL number is printed on the right battery tube calibration label. Cal number shifts of up to 10 counts are insignificant.
- 4) Internal tests are performed to further ensure scale integrity.

Final:

Either the reading returns to the last condition, or an error message is displayed.

SETUP
Function:

Allows Front Panel entry of seldom set parameters.

Action:

- 1) Press SHIFT & SETUP to enter the Setup menu. The message describes the parameter being set. To change the setting of the parameter push ENTER . Options are viewed by repeated pushing of the SELECT key. Selections are stored with the ENTER key. Pushing the CLEAR key will skip all remaining parameters and return the scale to normal operation. Pushing the POWER key will also exit the setup mode (and turn off the power).

Note: Not all the selections below are activated on every Porta-Weigh Plus. Legal-for-trade issues and application issues require certain menu items to be under the Calibrate menu (under seal, see calibration section), and certain items to be disabled. Any or all menu items can be eliminated under software control (contact factory for details).

Top Menu	Sub-Menu	Selections (highlighted selections are defaults)
FILTER		LOW, MEDIUM, HIGH
UNITS		POUNDS, KILOGRAM, TONS, METRIC Tons
AUTO OFF		ENABLED, DISABLED
REMOTE		ENABLED, DISABLED
LIGHTING		AUTOmatic On, Off
CONTRAST		(eight steps with message numerics at "123456")
HI SET PT	HI VALUE	Set value
	MODE	GROSS, NETGROSS, DISABLE
	RESPONSE	NORMAL, BLANK LCD, BLINK LCD (and Backlight)
	EXIT?	(exit Setpoint sub-menu)
LO SET PT	LO VALUE	Set value
	MODE	GROSS, NETGROSS, DISABLE
	RESPONSE	NORMAL, BLANK LCD, BLINK LCD (and Backlight)
	EXIT?	(exit Setpoint sub-menu)
TOTALIZE		MANUAL, AUTOmatic
EXIT?		Push ENTER to quit Setup, push SELECT to return to the top menu

FILTER

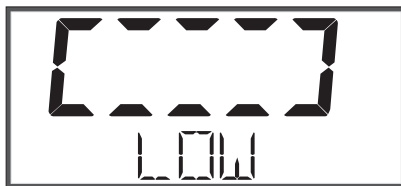

Use the LOW setting for most scale applications. It settles fastest and is intended for general use. Use the MEDIUM setting when the scale is being used under conditions that cause light to medium swinging. Use the HIGH setting when there is a lot of scale motion. There is a time penalty when using the HIGH setting. The user should wait at least 5-15 seconds to ensure that the final reading has settled (motion indicator off). (Not available in some legal-for-trade systems)

To change the filter settings:

- 1) Push SHIFT SETUP (Unless you are already in the Setup menu).
- 2) The message should read "FILTER". If it does not, push SELECT until it does.
- 3) Push ENTER. You are now in the Filter menu.
- 4) Push SELECT to change from LOW, MEDIUM or HIGH settings. When the desired filter setting is displayed on the message display, push ENTER.
- 5) Now you are back in the Setup menu. Push CLEAR to return to normal operation or push SELECT to scroll to a different setup operation.

UNITS



Units can be changed by scrolling through the choices with the SELECT key and pushing ENTER when the desired unit is displayed.

The actual FS range of the scale is dictated by the units in which it was calibrated in. For example, a 10,000 X 2 lb scale has a maximum overload of 10,400 lbs. If the units were changed to kgs by the setup menu, the range before overload would be 4717 kg (10,400 x .4536). The resolution will round out to 1 kg in this example. (Not available in some legal-for-trade systems).

To change Unit settings:

- 1) Push SHIFT SETUP (Unless you are already in the Setup menu).
- 2) Push SELECT until the message display reads "UNITS".
- 3) Push ENTER. You are now in the Units menu.
- 4) Push SELECT until the desired units are displayed, then press ENTER .
- 5) Now you are back in the Setup menu. Push CLEAR to return to normal operation or push SELECT to scroll to a different setup operation.

AUTO OFF

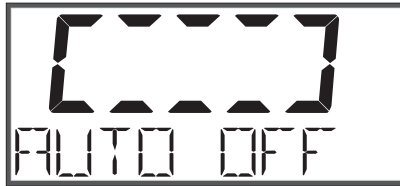

The AUTO OFF feature when enabled prolongs the battery life of the scale by turning the power off after 1 hour of non use. Any time a key is depressed (any key), or the detected weight is in motion, the 1 hour limit is reset. Therefore the scale will stay on indefinitely if the weight is changing or any key is pressed at least once an hour. This feature defaults to the enabled mode when initially calibrated. When disabled the scale will stay on, only the power key will turn it off.

To change the Auto Off mode:

- 1) Push SHIFT SETUP (Unless you are already in the Setup menu).
- 2) Push SELECT until the message display reads "AUTO-OFF".
- 3) Push ENTER. You are now in the Auto-Off menu.
- 4) Push SELECT to toggle between "ENABLED" and "DISABLED". When the desired mode is displayed, push ENTER.
- 5) Now you are back in the Setup menu. Push CLEAR to return to normal operation or push SELECT to scroll to a different

operation.

INFRARED REMOTE CONTROL



The infrared remote control option must be enabled in its setup menu to operate. When enabled, the remote circuitry adds a slight drain to the batteries even while the Scale is off. The approximate power-off battery life with Remote enabled is 40,000 hours vs. a remote disabled power-off battery life of 200,000 hours which exceeds the shelf life of alkaline batteries. (The remote option is not available in some legal-for-trade systems)

To enable/disable the Infrared Remote

- 1) Push SHIFT VIEW (unless you are already in the Setup Menu).
- 2) Push SELECT until the message display reads "REMOTE".
- 3) Push ENTER. You are now in the Remote menu.
- 4) Push SELECT to change between "ENABLED" and "DISABLED". When the desired mode is displayed on the message display, push ENTER.
- 5) Now you are back in the Setup Menu. Push CLEAR to go back to normal operation or push SELECT to scroll to a different setup operation.

LIGHTING



The backlight is normally controlled by a photocell which detects ambient light and determines if the backlight should be on or off (AUTOMATIC mode). Should the user desire the backlight can be permanently enabled (ON mode) or for increased battery life, perma-

nently disabled (OFF mode).

To change the Backlight Mode:

- 1) Push SHIFT SETUP (unless you are already in the Setup Menu).
- 2) Push SELECT until the message display reads "LIGHTING".
- 3) Push ENTER. You are now in the (Back) Lighting menu.
- 4) Push SELECT to change between "AUTO" (Automatic light sensing mode), "ON" (always on) (Warning: drains batteries at a higher rate) or "OFF". When the desired mode is displayed on the message display, push ENTER .
- 5) Now you are back in the Setup Menu. Push CLEAR to go back to normal operation or push SELECT to scroll to a different setup operation.

CONTRAST



Used to optimize the contrast of the liquid crystal display at various viewing angles. This is factory preset for optimal viewing from below the scale. By accomplishing eight steps, the viewing angle can be changed slightly to improve the contrast for other visual applications.

To change the Display Contrast:

- 1) Push SHIFT SETUP (unless you are already in the Setup Menu).
- 2) Push SELECT until the message display reads "CONTRAST".
- 3) Push ENTER . You are now in the contrast setting mode.
- 4) Push SELECT repeatedly to change the message display contrast. There are eight steps. When the desired contrast setting is reached, push ENTER .
- 5) Now you are back in the Setup Menu. Push CLEAR to go back to normal operation or push SELECT to scroll to a different setup operation.

HI SETPT (SETPOINT)

When the weight exceeds the set value the Porta-Weigh Plus can respond in a variety of ways. The normal response of the HI SETPT is to turn on an open Drain MOSFET which can be used to drive relays, lights, sirens, etc. (Contact the factory or your distributor for more details). Other HI SETPT responses possible are to blank the display or flash the reading on and off.

LO SETPT (SETPOINT)

When the weight falls below the set value, the Porta-Weigh Plus can respond in a variety of ways. The normal response of the LO SETPT is to turn on an open Drain MOSFET which can be used to drive relays, lights, sirens, etc. (Contact the factory or your distributor for more details). Other LO SETPT responses possible are to blank the display or flash the reading on and off. The Lo Set Point can be configured by customer order to become a second “greater than” a value response. This is typically used in overload warning systems and is standard in audible alarm option equipped units.

S E T



POINT ENTRY

A Set point is entered by the following procedure:

- 1) Press SHIFT ZERO to get into the Setup Menu.
- 2) From the Setup function, push the SELECT key until the message reads “HI SETPT” (or “LO SETPT”)
- 2) Push ENTER. This accepts that the HI SETPT can be entered.
- 3) The message display reads “HI VALUE”. Push ENTER.
- 4) The most significant digit flashes. Display reads “INPUT WT”. Push the SELECT key until the first digit of the desired weight value is displayed. Push ENTER. (The "CLEAR" key can be used to change an entry if needed)
 Note: To enter, for example, 100kgs on a 10,000 kg scale, the first two digits should be entered as zeros (00100).
- 5) The next most significant digit flashes. Use the SELECT key and the ENTER key to finish out the value entry.
 Note: With the IR Remote the value can be directly entered)
- 6) After the entire Hi Set Point is entered the display will step to “MODE”. Push ENTER. The first selection is “DISABLED”. This mode allows the user to program a set point without the

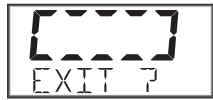

- setpoint actually operating. To enable the setpoint, push SELECT until either the "GROSS" mode or the "NET/GROSS" mode is selected. In the "GROSS" mode the setpoint will operate at the value set based on Gross Weight regardless of any tare value being subtracted. If this is the desired set point operation mode push ENTER. If the set point should operate relative to a tared weight the "NETGROSS" mode should be used. Use the SELECT key to change from "GROSS" to "NETGROSS" and then push ENTER. In this mode the set point will operate at the value which represents either a Gross weight or a Net weight.
- 7) The next selection is the Set Point "RESPONSE"...what should the scale do when the Set Point value is reached? Push ENTER. There are now three selections: The "NORMAL" response turns on the internal MOSFET which is connected to a user supplied alert device such as a siren or strobe light. Use the SELECT key to change the response to "BLANKLCD". In this mode the liquid crystal display weight reading blanks out and the message displays HI SETPT. The MOSFET functions as before. Use the SELECT key again to change to the "BLINKLCD" response. Weight readings continue, but the display alternates between a standard weight reading, and a "HI SET PT" indication. In all three modes, the overload condition will override the display mode.
 - 8) After the desired Set Point response is selected, push ENTER.
 - 9) The Set Point Menu is now back on the screen. The SELECT key can be used to return to any of above operations (VALUE, MODE, RESPONSE) if modifications need to be made. To quit and return to normal scale operation use SELECT until the message "EXIT?" appears and push ENTER, or push CLEAR (no shift required). This returns you to the Setup Menu. Again, push CLEAR to get out of the

menu and back to standard scale operation. Use the same procedure for a Low Set Point.

TO DISABLE A SET POINT

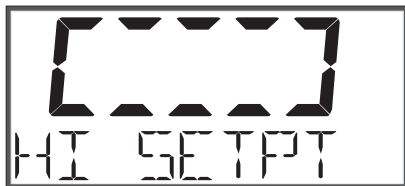

It is often useful to be able to set up a Set Point ahead of time and disable it for testing purposes.

- 1) From the Setup function, push the SELECT key until the message reads “HI SETPT” (or “LO SETPT”).
- 2) Push ENTER. This accepts that the HI SETPT is to be modified.
- 3) Push SELECT until the “MODE” message appears. Push ENTER.
- 4) Push the SELECT key until the message “DISABLE” appears. Push ENTER. This disables the Set Point and returns you to the Set Point Menu.
- 5) Push CLEAR two more times to get out of the SetPoint and Setup menus, or using the SELECT key, scroll to the next desired operation. To re-enable the Set Point, follow steps 1-3 above. On step 4 select the “GROSS” mode or the

“NETGROSS” mode.

PEAK HOLD



Function:

Allows the capture of a Peak Weight value. Useful for stress testing and related operations where the maximum weight measured is stored.

Action:

Selecting Peak Hold converts the scale to a peak reading display mode.

To Measure Peak Weight:

- 1) Select the appropriate filter for the application. The Low filter converts to a special high speed filter used for the Peak Hold mode only and should be used for peak hold applications such as cable break tests and other fast transient events. The Medium and High filters are best for maximum capacity or peak load tests because these filters will tend to eliminate peak values due to crane or boom “bounce”. See “Filters” in the SETUP section for more information.
- 2) Push SHIFT PEAK HOLD. Display reads “PK GROSS” or “PEAK NET”.

To Clear Peak Weight:

While the display reads “PK GROSS” or “PEAK NET” press SHIFT CLEAR.

Note: The last peak value is saved even when not in the peak hold mode unless it is cleared with the Shift Clear procedure above.

To Return to Normal Operation:

Push SHIFT PEAK HOLD. The message display will return to GROSS or NET, whatever the last standard mode was.

Note: The Tare, Tare Memory, Zero, Total, and View Total functions are disabled until the Peak Hold function is removed. Setup, Test, NET/GROSS, and ID# (Remote users only) are still active.

TARE MEMORY



Function:

- Allows storing and recalling a numeric or Semi-Auto Tare value. Up to 10 digital or Semi-Auto Tare values can be entered including the standard Tare available directly on the keyboard.
- The following functions are available: Apply a previously stored tare, store the current weight in Tare Memory (Semi-Auto Tare), enter a weight manually and store it in Tare Memory (Keyboard Tare), modify a previously stored Auto or Keyboard Tare.

Rules for Use:

- 1) The input value must be greater than zero and at least 1 display increment.
- 2) When storing an Auto Tare, the motion annunciator must be off. The manual keyboard total function is independent of motion and can be applied at any time.
- 3) Will not work in the Peak Gross or Peak Net modes.
- 4) Values can only be entered or applied when gross weight is the current weighing mode. However, the values associated with each Tare memory can be reviewed.

Action:

Selection is made of 1 of 10 Tare Memory values. The selection is then Set or Entered into to store or modify. An empty Tare Memory is designated by a zero and can not be used until a positive value is stored.

To apply a stored tare value:

- 1) Push SHIFT TARE MEMORY.
The liquid crystal display provides the value and number of the Tare memory. The numeric digits display the value stored

and the message display indicates the tare memory number in the form of "TARE x" (where x equals the tare memory number from 1 to 9 or is left blank for the base tare memory).
 Note: An asterisk (*) character shows to the left of the currently in use Tare Memory.

- 2) Use the **SELECT** key to scroll to the Tare Memory number/value desired. Infrared remote users can key in the Tare Memory number directly.
- 3) Push **TARE** .
 The selected Tare Memory value is subtracted from the current gross weight. The scale returns to standard operation in the Net mode.
 Note: To return to normal operation without changing the Tare mode, push **CLEAR** (no **SHIFT** required).

To store the current weight as a tare memory (Semi Auto Tare):

- 1) Push **SHIFT TARE MEMORY**. The tare value is displayed. The message provides the number (1-9) of the Tare Memory in the form of "TARE x". Use the **SELECT** key to scroll to the Tare Memory number that you wish to store the value in (Infrared Remote users can key in the Tare Memory number directly).
- 2) Push **ENTER**. This enables the store function. The message display indicates "AUTO x" (where x equals the tare memory number from 1 to 9 or is left blank for the base tare memory). The numerics show the current gross weight reading.
- 3) Push **TARE** or **ENTER** . If Tare is pushed, the new reading is applied immediately and the scale reads in the Net mode. Steps 4 and 5 are skipped. The current gross weight reading is transferred into the Tare Memory. If Enter is pushed the value is stored but not applied.
- 4) The Tare Memory can now be applied by pushing **TARE** (skip step 5), or a different Tare Memory can be selected with the **SELECT** key.
- 5) To return to normal operation without applying a Tare, scroll using the **SELECT** key until the message reads "EXIT?" and push **ENTER**, or push the **CLEAR** key.

To manually enter a stored tare value (keyboard tare)

- 1) Push **SHIFT TARE MEMORY**.
 The liquid crystal display provides the value and number of the Tare memory. The numeric digits display the value stored and the message display indicates the tare memory number in

the form of "TARE x" (where x = the tare memory number from 1 to 9 or is left blank for the base tare memory). Use the SELECT key to scroll to the Tare memory number that you wish to store the value in. (Infrared remote users can key in the Tare Memory number directly).

- 2) Push ENTER. This enables the "AUTO x" store function.
- 3) Push SELECT. This enables the manual keyboard tare value entry. The message display reads "INPUT Tx". The far left digit on the numeric display will flash. If a value was previously stored the value flashing will be the last entered Tare. This allows easy modification. All digits must be entered, therefore small tare values must be preceded by leading zeros.

Note: With Remote Control option, the Tare value can be entered directly from the numeric keypad. Skip to step 6.

- 4) Use the SELECT key to change the flashing digit. When the desired digit is displayed, push ENTER.
- 5) Repeat step 4 for the remaining digits.
- 6) When the last digit is entered the ENTER key is pushed again to return to the Tare Memory menu, or the CLEAR key can be used to delete the entire value and start over.
- 7) At this point the TARE key can be pushed to immediately apply the new tare or the SELECT key can be used to select another Tare Memory for entry or modification.

To manually enter a stored tare value (keyboard tare):

- 1) Push SHIFT TARE MEMORY.
The liquid crystal display provides the value and number of the Tare memory. The numeric digits display the value stored and the message display indicates the tare memory number in the form of "TARE x" (where x = the tare memory number from 1 to 9 or is left blank for the base tare memory). Use the SELECT key to scroll to the Tare memory number that you wish to store the value in. (Infrared remote users can key in the Tare Memory number directly).
- 2) Push ENTER. This enables the "AUTO x" store function.
- 3) Push SELECT. This enables the manual keyboard tare value entry. The message display reads "INPUT Tx". The far left digit on the numeric display will flash. If a value was previously stored the value flashing will be the last entered Tare. This allows easy modification. All digits must be entered, therefore small tare values must be preceded by

leading zeros.

Note: With Remote Control option, the Tare value can be entered directly from the numeric keypad. Skip to step 6.

- 4) Use the SELECT key to change the flashing digit. When the desired digit is displayed, push ENTER .
- 5) Repeat step 4 for the remaining digits.
- 6) When the last digit is entered the ENTER key is pushed again to return to the Tare Memory menu, or the CLEAR key can be used to delete the entire value and start over.
- 7) At this point the TARE key can be pushed to immediately apply the new tare or the SELECT key can be used to select another Tare Memory for entry or modification.

To delete a stored tare value:

Note: This procedure is not usually necessary because a new tare value can always be stored over an old value or the undesired value can just be ignored. Some situations using the ID Number function (See Infrared Remote section) may require that a tare value be deleted. Also to disable the NET/GROSS operation the selected Tare must be deleted.

- 1) Push SHIFT TARE MEMORY.
The message provides the value of the first Tare Memory in the form of "TARE x". Use the SELECT key to scroll to the Tare Memory number/value that you wish to delete.
- 2) Push ENTER. Push SELECT. The numerics show the current stored tare value with the left-most digit flashing.
- 3) Push CLEAR (no Shift required). The value will be eliminated and the memory location will indicate "0" on the numeric digits.

Note: The entire value will clear only if the left most digit is flashing. The Clear key will backstep delete any other digit.

- 4) A new Tare Memory can now be applied as described previously. To return to normal scale operation without applying a Tare, scroll using the SELECT key until the message reads "EXIT?" and push ENTER, or push the CLEAR key.

CLEAR

Function:

Used to clear numeric values and calculated values and to exit from

Setup menus.

Action:

Described per function. See Total, Set Points, Peak Hold, Tare Memory.

SELECT

Function:

Used to enter numeric values and select stored Tare values and to scroll through the setup menus.

Action:

Described per function. See Setup, and Total.

ENTER

Function:

Used to enter numeric values, setup parameters, and modify stored Tare values.

Action:

Described per function. See Setup, Set Points, Tare Memory, and Total.

SYSTEM INITIALIZE

This function should only be used when the operator is prepared for a complete setup and Calibration procedure. Under no circumstances should this procedure be initiated by the end user.

Function:

Clears the internal calibration settings. Starts the scale from the beginning. Usually used for board replacement, troubleshooting, or load cell replacement. This procedure does not alter factory features settings.

Action:

To initiate a system initialization, push the SHIFT key and then push the CALIBRATION key (inside the seal port). The message will

display “RESET”. A full calibration must follow this operation.

CALIBRATION (FRONT PANEL)

Function:

Calibration of the scale can be performed from the front panel after being enabled by pushing the calibration switch behind the seal port. To fully calibrate a Porta-Weigh Plus, the user is required to have an accurate test weight system of adequate capacity and in the case of a legal-for-trade Porta-Weigh Plus, the test weight system must be certified by the appropriate regulatory agency.

Important Note: At any point, the calibration procedures can be halted by turning the power off.

Action:

To enable Calibration; remove the seal port on the right side of the scale. Press the switch button in the hole. The Calibrate Setup Menu appears. Push the SELECT key to scroll through the various Calibrate Setup menu choices. Once the desired operation is displayed, push ENTER. To return to normal operation either scroll with the SELECT key to exit and push ENTER, or push CLEAR.

Calibration setup menu:

Note: Some legal-for-trade Porta-Weigh Plus units have more menu selections. The operation of these additional menu selections is detailed in the Setup section of this manual.

Top Menu	Selections
UNITS	POUNDS, KILOGRAMS, TONS, METRIC Tons
STD CAL	(perform a standard Cal)
FINE CAL	(fine adjust the calibration)
CAL RCAL	(Use the Rcal value for Cal)
AZM	ENABLE, DISABLE
EXIT	Push ENTER to quit setup, push SELECT to return to the top menu

Note: Skip the units section if the units are not being changed from what the scale was last calibrated in.

To select calibration units

- 1) Use the SELECT key to scroll to the “UNITS” message. Push ENTER.
- 2) Use the SELECT key to scroll through the Units options. When the desired units are displayed, push ENTER.

Standard calibration:

Standard Calibration is to be used for normal test weight or cal fixture calibration of the Porta-Weigh Plus.

- 1) Use the SELECT key to scroll to the “STD CAL” message. Push ENTER.
- 2) The message reads “Ø SCALE”. Remove all weight from the scale. When motion ceases push ZERO . Assuming the detected zero weight is within acceptable limits the message reads “WEIGHT” indicating it is time to add the test weight(s).
- 3) Pick up a test weight of at least 20% of capacity. (Note: A test weight of 50% or more of capacity is recommended for highest accuracy.) A legal-for-trade unit must be calibrated at 80% of capacity or greater.
- 4) Use the SELECT key to cause the displayed reading to match the value of the test weight.

Note: If the Select key is not pressed, the calibration weight will default to the scale full capacity. When a match is made push ENTER. Repeat for the remaining digits. When the last digit is entered the scale should be steady, as this can affect calibration accuracy. (Infrared Remote users can input the number directly and must enter leading zero's.)

For example: 5000 lbs of dead weights are available to calibrate a 2500 kg scale. Since $5000\text{lbs} = 2268\text{ kgs}$ (5000×0.4536), the number entered with the select and enter keys would be 2268.

- 5) Calibration is complete, push CLEAR to return to normal scale operation, or push SELECT to choose another Calibrate Setup function.

Fine calibration

Fine calibration is for minor adjustments to the calibration and is usually not necessary. It is especially useful in hydraulic cal fixtures for fine adjustments.

- 1) Use the SELECT key to scroll to the “FINE CAL” message. Push ENTER.
- 2) Pick up a test weight of (or set the hydraulic tension to) at



least 50% of capacity. The weight is indicated on the numeric digits.

WARNING: This function will not work unless the scale is loaded at 45% of capacity or more.

- 3) Use the **SELECT** key to cause the displayed reading to move up slightly. Use the **CLEAR** key to cause the reading to move down. Each push of the Select or Clear key causes the calibration to shift by 1/4 displayed count. When the displayed reading is acceptable push **ENTER** .
- 4) Fine Calibration is complete, push **CLEAR** to return to normal scale operation, or push **SELECT** to choose another Calibrate Setup function.



Calibrate with RCal

Calibrate with the Resistor Calibration number.

Caution. Cal RCal is for emergency calibration when test weights or a calibration system is not available.

- 1) Remove the right (facing the back) battery tube. On the calibration label is a printed RCal value. Make a note of the value and reinsert the battery tube. Turn the scale power on and push the calibrate enable switch behind the seal port.
- 2) Use the **SELECT** key to scroll to the “CAL RCal” message. Push **ENTER**.
- 3) The message reads “Ø SCALE”. Remove all weight from the scale. Push **ZERO**. The scale will internally zero when motion ceases and assuming the detected zero weight is within acceptable limits.
- 4) Use the **SELECT** and **ENTER** key to cause the left most digit of the displayed reading to match the RCal value noted earlier. Repeat for the remaining digits. Push **ENTER**.
Note: The RCal value is stored in internal memory and will show up as a default value. If this is the desired value just push the enter key.
- 5) Cal RCal is complete, push **CLEAR** to return to normal scale operation, or push **SELECT** to choose another Calibrate Setup function.

To enable/disable AZM (Auto Zero Maintenance)

- 1) Use the **SELECT** key to scroll to the “AZM” message. Push

ENTER.

- 2) Use the SELECT key to scroll through the AZM options. When the desired mode "ENABLED" or "DISABLED" is displayed push ENTER.



Caution: Disabling Auto Zero Maintenance will degrade temperature and drift performance of the Porta-Weigh Plus.

Disabling the AZM is only intended for certification testing.

Under no other circumstances should the scale be used with the AZM disabled.

When calibration is finished:
Seal the Calibration Port.

Calibration cycle:
Measurement Systems International recommends that the Porta-Weigh Plus is calibrated at least once a year by a qualified scale technician with certified calibration standards.

EIA-232-D SERIAL OUTPUT OPTION

Function:

The EIA-232 output is used in conjunction with the Infrared Remote Control to output weight and total data to a printer or can be used for two-way communications with a computer.

Electrical Conformance:

The electrical characteristics of the serial output is configured to conform to the EIA Standard EIA-232-D. Cable connections include RXD, TXD, Ground, CTS, and RTS. (CTS / RTS handshaking is not currently supported, consult factory)

Configuration:

The Porta-Weigh Plus serial port option is factory configured only. Standard data configuration is:

Baud Rate:	9600
Data Bits:	8
Parity:	None
Start Bits:	1
Stop Bits:	1

By customer order, the standard configuration can easily be changed. Available configurations include any combination of the following

settings:

Baud Rate: 300, 600, 1200, 2400, 4800, 9600, 19200, 38400
 Data Bits: 7 or 8
 Parity: None, Even, Odd
 Start Bits: 1
 Stop Bits: 1 or 2

Data Format:

Each transmitted reading consists of 24 to 33 characters including 10 customizable characters. The preamble (five characters) is intended

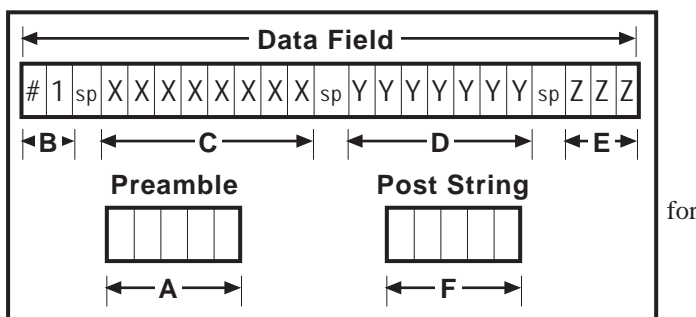

printer control characters but can be any ASCII characters. The post string (five characters) is used for Line Feed or other end-of-line control characters. In addition, there is a 5 character initialization string transmitted when the Porta-Weigh Plus is turned on. These three character strings are custom programmed to customer specifications into the Porta-Weigh Plus at the factory. The standard configuration is optimized for a 24 column printer, available from several manufacturers. Contact the factory for a list of plug compatible printers. The transmitted data is grouped in fields, A through F, defined as follows:

- A. Preamble field: up to 5 characters can be sent for control characters and printer formatting. The standard configuration eliminates the preamble.
- B. ID Code Field: the first character is the number sign, the second character is a digit from 1 to 9 indicating the ID number.
- C. Weight Field: eight characters of weight or total data. "0" to "9", including a minus sign and a decimal point if appropriate.
- D. Mode Field: seven characters that indicate the printed weight

modes: GROSS, NET, TOTAL, PKGROSS, PKNET

- E. Units Field: three characters that indicate the weight unit: lbs, kgs, ton, mtn (Metric Tons)
- F. Post String: up to five control characters used in printer interfacing. Default character is LF (line feed).

OPERATION

The Porta-Weigh Plus serial port can be used in two modes:

Infrared Remote Control Option:

This is a print on command mode which works when the print button on the remote control is activated.

Computer Control:

The computer can control and receive data from the Porta-Weigh Plus through the use of simple ASCII commands. These commands can be sent through the use of a data communications program, or a custom Basic program.

The following table details the ASCII commands for controlling the operation of the Porta-Weigh Plus model 4300.

COMPUTER OPERATION OF THE MSI PORTA-WEIGH PLUS

FUNCTION	ASCII Code	Comments
Power Off	A	Power on must be from the Porta-Weigh Plus
Zero	B	Subject to motion rules
Net/Gross	C	Function toggles, query scale for current mode
Tare	D	Functions only in the Gross mode
Total	E	Add the current weight to the total register or in auto-total mode, total on/off
View Total	F	Toggles, query scale for current mode
Calibrate	G	Internal switch must be pushed
Shift	H	Display test and diagnostics
ID Number	I	Must be followed by a number 1-9
Print	J	Will print the current display mode
Clear Selected Mode	K	Sets scale to GROSS Mode
Test	L	Display test and diagnostics
Setup	M	Allows changing setup parameters
Peak Hold	N	Toggles, query scale for current mode
Tare Memory	O	Must be followed by a number 1-9
Clear	P	Will clear totals if in view total mode
Query Selected Mode	Q	Poll for current scale mode
Numerics	0-9	Used with Tare Memory, setpoints, etc.

The following functions are intended for factory internal use. Will not function unless the seal port Calibrate and CLEAR keys are depressed immediately after power on.

Calibrate Clear	R	WARNING This completely clears the Calibration Constants
Manager Calibrate	W	Configuration manager calibrate mode
Manager Upload	X	Upload the scale configuration to host μ C
Manager Download	Y	Download a new configuration from the host μ C to the Porta-Weigh Plus

The Porta-Weigh Plus does not have an EIA-232 input buffer. This limits how fast commands can be sent. Some delay (~10ms) between ASCII commands should be included in any software written to control the Porta-Weigh Plus. The speed of data transmission is limited only by the baud rate and the user interface. The response to a print command is virtually instantaneous. However, transmission of new, updated, data from the Porta-Weigh Plus is limited by the speed of the A/D conversion, and the filter setting. The low filter limits the data update to a 2 per second rate, the medium is about 1 per second, and the high setting has about a 1 per 2 second update rate. These

speeds must be taken into account to prevent the printing of duplicate data.

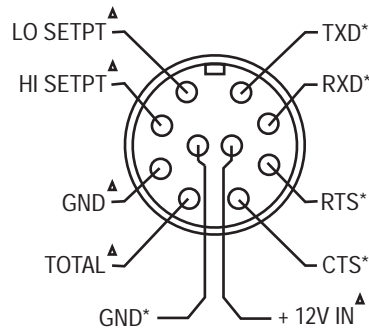

* Standard EIA-232-D interface connections

▲ Standard setpoint interface connections

End view of interface receptacle

When the EIA-232 option or setpoint option is used, the interface receptacle shown is installed in the Porta-Weigh Plus front casting and the mating connector is supplied. Pins 1-5 are for the EIA-232 interface and pins 6-10 are for setpoint interface.

PORTA-WEIGH PLUS BASIC PROGRAMMING EXAMPLE

Note: The following BASIC program is intended as an example only. Measurement Systems International does not guarantee that it will run without modification on any personal computer. There can be significant timing and compatibility differences from PC to PC.

Programming Example:

This basic routine interrogates the scale as to what the currently selected modes are, prints them, and then prints out the current weights for GROSS, NET, TARE (A valid Tare Weight must be stored prior to running this program), Peak GROSS, and VIEW TOTAL. This routine is written in GW-BASIC and is configured to operate out of COM Port 1. Baud rate and EIA-232-D configurations are factory set to 9600 baud, 1 stop bit, 8 data bits, and no parity.

```

100 CLS:LOCATE 1:DEFINT A,Z:                REM Initialize Screen
110 COMFIL$="COM1:9600,N,8,1,RS,CS0,DS0,CD0":  REM Setup PC Comm Port
120 OPEN COMFIL$ AS #1
130 PRINT #1,"Q":                          REM Query PAW+ Selected Modes
140 A$=INPUT$(1,#1):A=ASC(A$):             REM Input Mode Data
150 IF A$ < " " AND A$ > "/" THEN PRINT "ERROR Wrong Data Returned":GOTO130
160 IF A AND 1 THEN W$="ON " ELSE W$ = "OFF": REM Auto Total Mode
170 IF A AND 2 THEN X$="ON " ELSE X$ = "OFF": REM View Total Mode
180 IF A AND 4 THEN Y$="ON " ELSE Y$ = "OFF": REM Peak Hold Mode
190 IF A AND 8 THEN Z$="ON " ELSE Z$ = "OFF": REM Net Mode
200                                         REM Print current selected Mode status
210 PRINT "AUTO TOTAL IS ";W$;" VIEW TOTAL IS ";X$
220 PRINT "PEAK HOLD IS ";Y$;" NET MODE IS ";Z$
230 GOSUB 400:GOSUB 410:                  REM Set Gross Mode, Print GROSS Weight
240 PRINT #1,"C":GOSUB 410:              REM Set Net Mode, Print NET Weight
250 PRINT #1,"D":GOSUB 410:              REM Display Tare, Print TARE Weight
260 GOSUB 400:GOSUB 430:                  REM Reinitialize to GROSS, Delay
270 PRINT #1,"N":GOSUB 410:              REM Set Peak Hold Mode, Print Peak Wgt
280 GOSUB 400:GOSUB 430:                  REM Reinitialize to GROSS, Delay
290 PRINT #1,"F":GOSUB 410:              REM Set View Total, Print TOTAL Weight
300 END:                                   REM End of Program,start of subroutines
400 PRINT #1,"K":RETURN:                  REM Set Gross Mode subroutine
410 GOSUB 430:PRINT #1,"J":              REM Delay, then tell PAW+ to transmit
420 A$=INPUT$(24,#1):PRINT A$:RETURN:    REM Capture data, print to screen
430 FOR I =1 TO 500:NEXT I:RETURN:       REM Delay subroutine

```

Note: The time of the delay routine was set for a 20MHz CPU. Adjust up or down as needed for other speeds.

INFRARED REMOTE CONTROL

Operating the Porta-Weigh Plus with the Infrared Remote Control is identical to operating the scale from the standard keyboard. However, additional features are available using the remote and certain cautions are warranted.

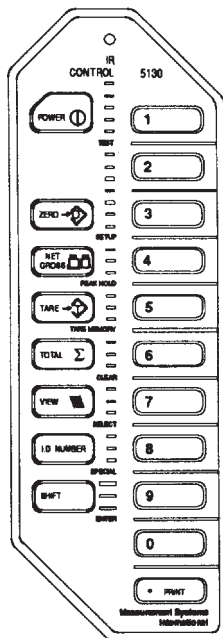

The Infrared Remote is highly directional and requires fairly accurate aiming to achieve the maximum operation range. The shape of the remote is designed to help in aiming. Aiming becomes less critical as the distance decreases. The differences between front panel operation and remote operation are described below.

Remote Power On/Off:

To turn the Porta-Weigh on with the remote requires that the power key is held down until the scale turns on... usually about 1 to 2 seconds. Power-on is the only function that requires more than a short push of the button. Power-off is instantaneous. Holding down the button on power-off might cause the unit to turn back on.

ID Number:

Up to 9 separate ID codes are available. Each ID code has a total register, and a tare register. Weighing setups can be prearranged by setting the ID number and establishing a Tare Memory for that ID number. Then the next time that particular ID number is selected the proper tare value is already established, and any previously stored total value is enabled.

Action:

The ID number is changed by pushing “ID NUMBER” and then the desired number (1-9). The default ID number is 1 which is the only available ID without the remote.

Printing:

Pushing the Print key on the remote will cause the current displayed value to be printed (requires EIA-232 option).

Action:

- To print the Gross, Net or Total values, first use the NET/GROSS key or the VIEW Σ key to place the desired mode on the display, then push PRINT.
- To print the Tare value: While in NET mode push TARE followed by PRINT.



Caution: Do not accidentally push the Tare key while in Gross mode as this will clear the old tare and establish a new tare.

Numeric Entry

The Tare memory values and Setpoint values can be directly entered from the remote. Instead of using the select key to scroll through values, push the desired number directly. The Tare memory number can also be accessed directly. (i.e. SHIFT - TARE - 3 will directly select Tare memory #3).

REMOTE CONTROL BATTERY REPLACEMENT

Type:

Standard 9 volt (NEDA/ANSI 1604 A, IEC 6LR61). alkaline type is preferred due to high LED peak currents. There is storage space for a spare battery internal to the remote.

When to Change:

The internal 9 volt battery needs replacing when the indicator LED is no longer visible when any button is pushed. The operating range of the remote will gradually decrease. When the range is insufficient for your normal mode of operation, replace the battery (even if the LED is still visible).

Installing/Changing:

- 1) Turn the remote unit over. Remove the three phillips screws with a number 2 phillips head screwdriver.
- 2) Turn the unit right side up. Pop the front panel out by applying pressure to the lower left corner of the blue urethane case thus exposing a corner of the front panel / switch assembly. With a flat screwdriver blade; carefully pry out the switch from the urethane case by working the screwdriver up the left edge of the switch assembly. Be careful not to insert the screwdriver too deep as you may damage the internal electronics.
- 3) Fold the switch assembly to the left side of the unit, exposing the battery and the printed circuit board.
- 4) Pull the battery connector off the battery. Remove the battery by tilting it up sideways.
- 5) Install the new battery by tilting it in sideways and wedging it in the small indented region between the printed circuit board and the case wall.
- 6) Reconnect the battery connector. Check for operation by pushing any key on the front panel and ensuring that the indicator LED is lighted. If it does not, check that the keyboard connector is still seated properly and the battery is fresh.
- 7) Replace the front panel / switch assembly by centering it over the open area and pressing evenly around the edges until it seals.
- 8) Replace the three screws. Make sure the screw seal gaskets are in good condition.

Infrared Remote Comments:

- Due to the sensitivity required to allow for full sunlight operation, it is possible to overload the input to the infrared remote receiver in the scale if the remote is too close. This situation is characterized by erratic remotely controlled operation. The simple remedy for this is to not aim directly at the scale, but aim slightly off center when very close.

- The range of the remote is optimized when the scale is 8 feet or more off the ground. The infrared sensor is aimed slightly down to help diminish sunlight overload. When the scale is closer to the ground, aim the remote up into the infrared window from below. If the scale is used normally very low to the ground it is sometimes possible to bounce the infrared signal off the ground and up into the sensor.
- Using SHIFT key functions requires that the keys are entered in rapid fashion. If more than five seconds pass between the SHIFT key and subsequent key presses, the scale will forget that you pushed SHIFT. This could mean, for example, that the scale will turn off rather than go into the test function (Shift, Power).
- The ID# function has a five second maximum window for the number entry otherwise the ID# will remain as before.
- As shipped, any Measurement Systems International infrared remote will operate any Porta-Weigh Plus. It is possible, by special order, to encode the infrared transmissions so that a separate remote is required for each different Porta-Weigh Plus. Up to eight channels are possible. Contact the factory for more details.

SPECIFICATIONS

Accuracy

$\pm 0.1\%$ of applied load for all capacities 100,000 lbs (50,000 kg)
and below $\pm 1.0\%$ > 100,000 lbs (50,000 kg)

Maximum Resolution

12,500 displayed counts
50,000 to 80,000 counts internal

Standard Industrial Resolution

5000 displayed counts

Display

6 digit 1.6"/40 mm high numeric liquid crystal (weight display)
8 digit 0.8"/20 mm high alphanumeric liquid crystal display
(message / units display)
Annunciators for measurement modes
Sunlight visible light emitting diode indicator for Totalization
Photocell activated electroluminescent backlighting

Filtering:

Low, Medium, High (switch selectable)

Power:

8 standard D Cells

Operating Time:

2000 hours typical with occasional use of the LCD backlight. 400
hours with continuous use of backlight.

Temperature Range

-20° C to +60° C Operating (-4° F to 140° F)
-40° C to +80° C Storage (-40° F to 176° F)

Enclosure

NEMA IV, Alodined cast aluminum

Safe Overload

200% of rated capacity

Ultimate Overload

500% of rated capacity except 70,000 and 100,000 lb models,
450% of rated capacity

Hook

Crosby-Laughlin S-1 Timken Bearing swivel hook or equivalent

Top Eye Nut

500 through 30,000 pound capacity, Crosby-Laughlin or equivalent

Top Shackle

50/70/100,000 pound capacity, Crosby-Laughlin or equivalent

OPTIONS

- NIST and OIML legal-for-trade approved (approvals pending). Contact factory for US and International specifications Class III and III.L.
- Infrared full function remote control.
All functions are controllable with the MSI infrared remote control. This weather sealed, pocketable device has an outstanding range of up to 30 meters (100 feet) in ideal conditions and 5 meters in broad daylight. Unit functions are identical to the front panel with the addition of a Print command (requires EIA-232 option), a 10 key numeric entry capability, and adds ID code number entry with up to 9 totalization memories. Uses 1 or 2 standard 9V batteries.
- EIA-232 and external I/O .
2 way EIA-232-D communications are provided for interfacing the Porta-Weigh Plus to a remote printer or computer. Requires cable pinouts.
External Setpoints: Provides 2 open drain contacts for interfacing to external devices such as warning lights, process relays, or sirens.
External Power: Allows connection of a 6 - 15 Vdc external power source.
- Audible overload alarm.
Coupled with the internal setpoints, a single (pulsing) or dual level (pulsing or steady tone) overload alarm can be set at any weight. Can also be used for an in-limits or out-of-limits indicator.
- AC power.
115 VAC 50/60 Hz or 230 VAC 50/60 Hz. Recommended for stationary applications only.
- Extra loud siren.
114 dB loud siren for overload warning.
- Dual Load Cell.
A second slave load cell can be connected allowing summed dual load cell operation. The load cell interconnect cable is limited to 33' (10 meters). Specify interconnect cable length.
- Substitute Stainless Steel Link for swivel hook.
- Oversized Top Lifting Eye or Shackle.

THE MSI LIMITED WARRANTY

MEASUREMENT SYSTEMS INTERNATIONAL, INC., WARRANTS load sensing elements and meters against defects in workmanship and materials for a period of one year from date of purchase and warrants electrical cables and batteries against the same defects for a period of ninety (90) days from date of purchase.

Any device which proves defective during the warranty period will be replaced or repaired at no charge; provided that the defective device is returned to the Company freight prepaid.

In no event shall the Company be liable for the cost of any repairs or alterations made by others except those repairs or alterations made with its specific written consent, nor shall the Company be liable for any damages or delays whether caused by defective workmanship, materials or otherwise.

The Company shall not be liable for any personal injury or property damage resulting from the handling, possession or use of the equipment by the customer.

The warranty set forth herein is exclusive and is expressly in lieu of all other warranties, express or implied, including without limitation any implied warranties of merchantability or fitness, or of any other obligations or liability on the part of the Company.

The liability of the Company under this warranty is limited solely to repairing or replacing its products during the warranty periods; and the final judgement and disposition of all claims will be made by MEASUREMENT SYSTEMS INTERNATIONAL, INC.

PROPER LOADING PROCEDURES

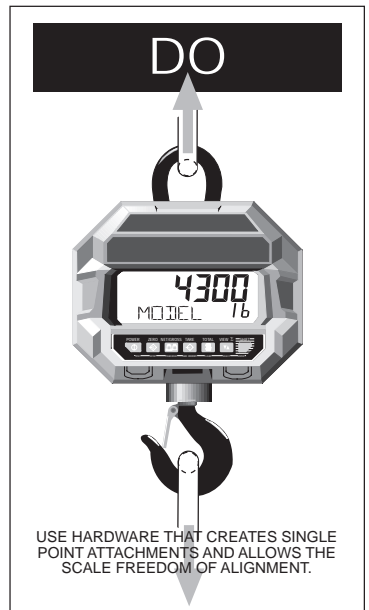
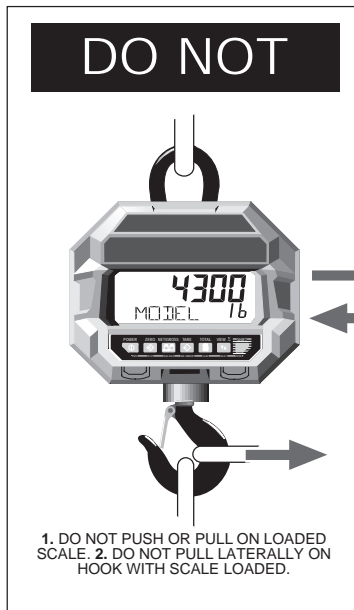
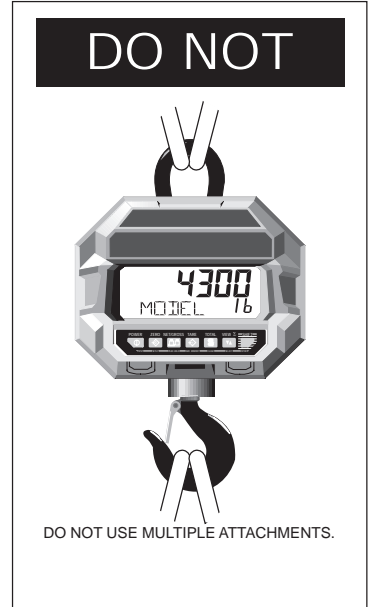
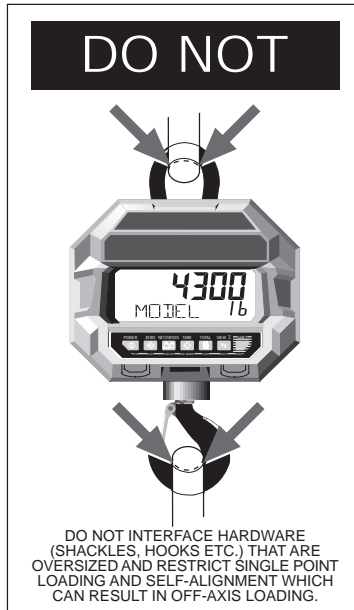

PUB.PLP-01-95



© 1997 by Measurement Systems International
Printed in U.S.A.
PUB.146-01-91B



Measurement Systems International

14240 INTERURBAN AVENUE SOUTH
SEATTLE, WASHINGTON 98168-4660 U.S.A.
PH: 206-433-0199 • FAX: 206-244-8470
WEB: www.msiscales.com • Email: info@msiscales.com